

**Root Cause Analysis Report
PBF Energy Torrance Refinery
February 22, 2019 Propane Release Incident**

Summary of Incident:

On the morning of February 22, 2019, during the removal of safety valve 52SV41 located in the South Oil Movements Area #52 of the refinery, a release of an estimated 2600 lbs. of propane occurred, resulting in an injury to the craft person performing the valve removal. The injury involved propane burns to the hands and arms of the crafts person. The crafts person was treated at a nearby hospital and returned to work with restrictions.

A brief Timeline of the incident is as follows:

7:15 hrs.	Process operator and craft person perform joint job visit
8:00 hrs.	Work permit issued by operator to perform valve removal
8:10 hrs.	52SV41 valve removal commenced by crafts person, resulting in propane release
08:11 hrs.	Craftsmen attempted to re-install the new Pressure Relief Valve (PSV)
~8:12 hrs.	Water is applied to release location to mitigate any potential flammable hazards
9:16 hrs.	Release stopped by isolating the section of pipe

On February 22, 2019 at 12:00 PM, incident investigation was commenced.

Agency Notification and Response:

Torrance Fire Department (TFD) was notified and responded to the event.

Emergency Response Actions:

The operator cleared the area and applied water to the release location to mitigate any potential flammable hazards. Torrance Refinery Fire Brigade (TFB) was notified responded, and took over the incident response. Subsequently, TFD was notified, responded, and assisted with the incident..

There were no offsite impacts from this incident.

Material Released:

The material released was propane from the discharge piping of propane pump 52G42 where safety valve 52SV41 is located. This incident met the API Tier 1 Process Safety event criteria.

Meteorological conditions:

The weather conditions during the incident were as follows:

- Clear and dry
- Average wind speed was 2.3 miles per hour and changing direction between 337 and 247 degrees
- Temperature was about 49°F.

Injuries:

One OSHA recordable to crafts person due to restricted work. The injury involved propane burns to the hands and arms of the crafts person.

Community Impact:

There were no offsite impacts from this incident.

Incident Investigation of the Incident:

This incident investigation focused on the loss of primary containment that occurred on discharge piping of 52G42 located in the South Area # 52 Area and the crafts person's injury that occurred while performing the activity of replacing the safety valve 52SV41.

Background:

52SV41 is the safety valve located on the discharge piping for 52G42 pump. This pump provides propane to a vaporizer located in the Hydrotreater (HDT) unit # 24. See attached Drawing # 1).

On the afternoon of February 20, 2019, the Process Mechanical Planner (PMC) instructed the night shift process crew to prepare the safety valve for replacement because it was suspected of leaking through internally. In preparation for the replacement, the night crew operator prepared the process plan, isolated, and started de-pressuring the system to the vapor recovery-Flare system. The process plan included EIL (energy isolation log sheet), OPE checklist (Opening Process equipment), and NZE form (Non Zero Energy form) believed to be required for opening the union on the downstream side of the safety valve. The head operator helped the operator to identify two energy isolation points located in the HDT by using the Piping & Instrumentation

Drawing's (P&ID) associated with the equipment.

On the morning of February 21, 2019, the NZE form was given to the day shift Head operator so he could obtain the Business Team approval and signatures for the valve replacement. A pre-work meeting was held with the appropriate mechanical and process supervision and authorization was obtained to open the safety valve downstream union without proving zero energy.

Mechanical craft persons attempted to perform the job late afternoon of February 21, after the NZE form approval was obtained, but during the site visit they were informed by the operator that the system was not ready because it was still de-pressuring to the flare. The craft persons checked the system pressure gauge and they reached the same conclusion.

Drawing # 1

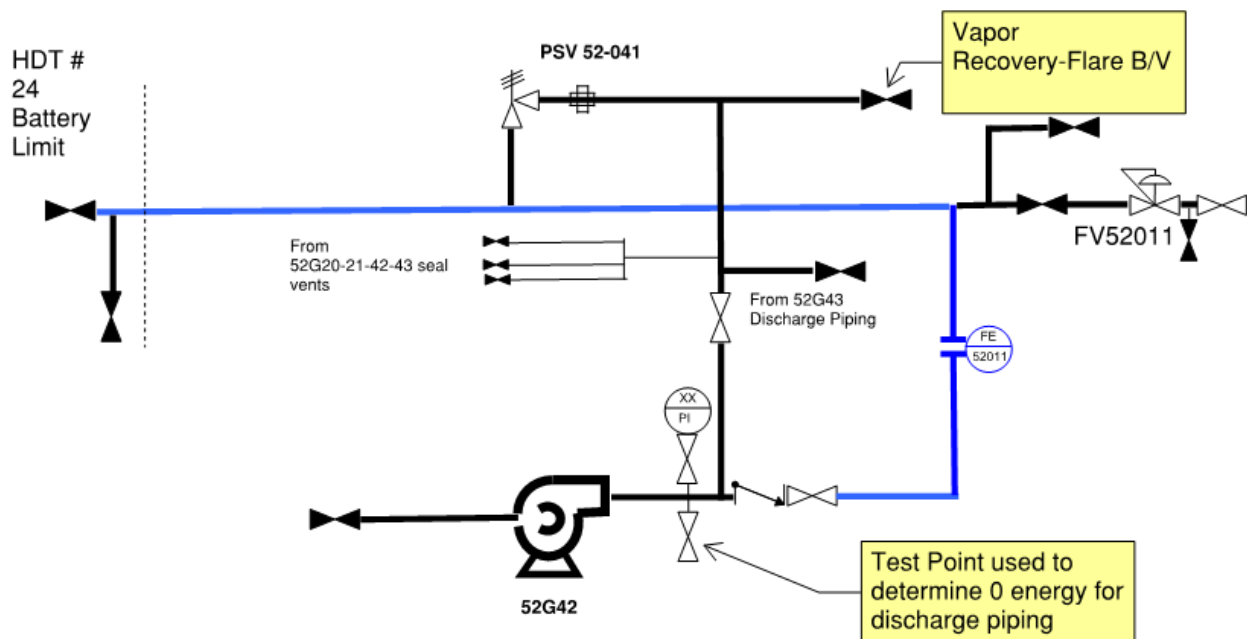

52SV041 Release:

Around 7:00 am on February 22, 2019, the craft persons were instructed by the Mechanical Front Line Supervisor (MFLS) to perform the 52SV041 valve replacement. The crew arrived at the job site where they met with the operator. The operator closed and LOTO'ed (locked out tagged out) the last valve (Flare). The operator and the crew then verified the pressure of the system by opening the test point. The test point confirmed zero energy. After this verification of the isolation points per energy isolation log (Joint Job Visit), the crew was signed on to perform the job by the operator at 8:00 am.

The IP (the crafts person that was injured) started unscrewing, with the help of another CP #2 (second craft person), the union located on the downstream side of the safety valve per NZE form requirement. As expected, a small amount of residual propane material escaped upon the pipe opening. IP removed the safety valve downstream nipple and union and he gave it to CP #2 to install on the new safety valve.

IP started slowly unscrewing the upstream side of the safety valve until it popped off due to unexpected pressure. Propane began to release from the ¾" opening where the safety valve had been. IP attempted to install the new safety valve twice but he was not successful. Both the IP and CP #2 left the scaffold and went to a secure location on the west side of the area.

The operator who was watching the job promptly applied water on the propane release to mitigation potential flammable hazards and cleared the area. He then notified TFB and requested support.

TFB arrived and managed the leak by applying additional water. The propane release was stopped by isolating the section of pipe around 9:16 am.

The investigation found that the discharge piping contained residual propane because the preparation plan was less than adequate. Specifically, a wafer check valve on the discharge of the pump prevented the piping from being completely emptied to the flare header through the pump suction piping. This issue was not found during the process plan verification step because the Head Operator relied on the operator's experience and knowledge. As a result, the wafer check valve was not identified prior to the job.

Furthermore, the investigation found that at the time of the job execution the process operator did not perform an independent evaluation of the system. As a result, was wafer check valve issue was not discovered through this evaluation.

Root Cause Methodology:

The investigation team applied the ABS Consulting SOURCE incident investigation techniques (ABS methodology), which is the methodology that Torrance Refinery uses for incident investigations. The basic steps of the ABS methodology are:

- (1) Gathering all data relevant to the investigation;
- (2) Developing causal factors using a systematic method based on the data;
- (3) Determining root cause of each causal factor; and
- (4) Developing recommendations directly relating to causal factors and the incident sequence.

Materials Reviewed, Inspections, and Analyses for Incident Investigation:

For the area of piping where the incident occurred, there are no applicable Process Hazard Analyses (PHA), Damage Mechanism Reviews (DMR), Safeguard Protection Analyses (SPA), or Hierarchy of Hazard Control Analyses (HCA).

As part of the investigation into this incident, the investigation team conducted witness interviews and inspected the release area. Additionally, the investigation team reviewed job work permits, EIL, OPE checklist, NZE form, LOTO list, P&IDs, process plan, Job Hazard Analysis (JHA), Safety Data Sheet (SDS), and applicable procedures.

Root Cause Analysis:

Using the ABS methodology, the following root causes and recommendations (see below) were identified.

Root Cause # 1: The wafer check valve downstream of the pump was missed, invalidating the test point selected to verify zero energy on the PSV upstream piping.

Root Cause #2: The process plan was not validated by a Head Operator (or equivalent) as required by Equipment Opening and Safe blinding procedure.

Root Cause # 3: The operator answered the question on the work permit regarding equipment readiness, based on information written on the process plan by another operator, and did not perform an independent evaluation of the field conditions.

Root Cause # 4: Hazard recognition of job was less than adequate prior to start of the job and during the incident resulting in crafts person inappropriately placing his person (Hands/forearms) in direct contact with propane in an attempt to stop the release.

Recommendations / Hierarchy of Hazard Control Analysis (HCA):

Pursuant to the CalPSM and CalARP Program 4 regulations for a major incident, the investigation team also conducted an HCA on recommendations¹ to address the root causes above. The results of the HCA are presented below:

¹ All recommendations are considered permanent unless otherwise noted in the table below.

**Root Cause Analysis Report
Torrance Refining Company
February 22, 2019 Propane Release Incident**

Final Recommendation				
#	Recommendation	Anticipated Date of Completion	Root Cause	ISS/HCA Level Strategy
1	Develop training course on how to create process plans that secure the entire system. Provide training to the North Oil Movements (NOM) operator personnel. As part of this, develop a program to validate that personnel are trained and still in compliance with the site procedures.	12/31/19	1	Level: Procedural
2	Create a process plan check list (Equipment Preparation Plan) to bridge the Organization knowledge until operator training (Recommendation #1) has been completed. (Interim)	8/31/19	1	Level: Procedural
3	Modify Operator Training: Operator Review Board to require a passing grade on the understanding of P&ID symbols and usage of P&IDs. (Permanent)	10/31/19	1	Level: Procedural
4	Reinforce expectations with all Level 4 and Head operators that OPE plans must be validated by a Level 4 or Head operator. In addition, reinforce expectations that operators are responsible for confirming work permit conditions and are required to do an independent evaluation of the field conditions (Interim)	8/31/19	2, 3	Level: Procedural
5	Review current work permit audit program to ensure, verification, measurement and improvement feedback mechanisms are in place for the OPE and work permit procedures	12/31/19	2, 3	Level: Procedural
6	Provide Torrance maintenance department with hazard recognition training and proper response to various hazards, including a pressurized propane release.	12/31/19	4	Level: Procedural
7	Issue Incident Bulletin with the following discussion points: performing hazard recognition before start of work including reviewing relevant SDSs for chemicals and perform a last minute risk assessment (a type of Loss Prevention Self-Assessment (LPSA) (Interim)	7/31/19	4	Level: Procedural
8	Develop a site-wide JHA standard for maintenance and operating crews as part of the Process Safety Management System (PSMS) standard, including periodic audits to ensure compliance with the standard.	12/31/19	4	Level: Procedural